

A Light-Controlled Motor

Laboratory Brief

We now start the process of designing a self-navigating car. Specifically, we will merge two voltage-divider circuits with two “motor-drive” circuits and construct a car that will navigate from the shadows and stop under a bright light. You can imagine this behavior with, say, a planetary rover that must seek sunlight for recharging. In the process, we will gain some exposure to a device known as a transistor.

Learning Objectives

- Identify simple data from a datasheet.
- Modify a voltage-divider circuit to utilize a sensor.
- Assess and verify the function of a photo-resistor-based voltage-divider.
- Learn to allow for tuning of designs.
- Relate observations to earlier predictions based on circuit models.
- Use current knowledge to design a future project.

Introduction

Let’s begin by considering one of the most-simplistic methods of motor-speed control: the use of a current-limiting resistor. We know that smaller series resistances allowed larger current flow through the motor and larger series resistances choke off the current through the motor. The choice of our current-limiting resistor effectively sets the speed of the motor. See Figure 1 where we imagine a variable resistor could be used to adjust the motor speed.

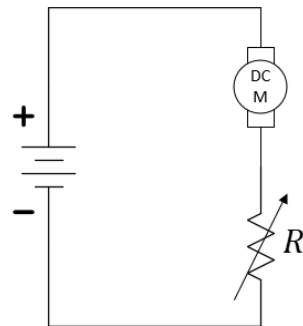

Figure 1: Motor speed control with a variable resistor.

The problem with using a hand-tuned resistor (like the potentiometer in your kit) for controlling motor speed is that it has no **sensor** input to control its setting. In robotics and other electronic sensors (light, heat, sound, etc.) allow for *autonomous* actions rather than direct control from human commands. For our light-seeking robot, we desire a variable resistor that changes its value based on light. Let's start by identifying a device that will change its effective resistance based on *voltage* (we'll get to *light* later). Enter the transistor.

Transistors will be studied in much greater detail in the lecture. Transistors are complex devices with various modes of operation. They are used to amplify signals. They are used as switches. Here, we will use a *transistor* as a *variable resistor*. Find the power Metal-Oxide-Semiconductor Field-Effect Transistor (MOSFET) with part number 30N06L in your electronics kit. The datasheet can be found at <https://cdn.sparkfun.com/datasheets/Components/General/FQP30N06L.pdf>. The device has three pins, a Gate (G), a Drain (D), and a Source (S). This device is called an n-channel enhancement MOSFET or *nMOS* for short.

Figure 2 shows two similar, but different, symbols for the nMOS device. Be careful to remember that these are only symbols for a more complex device. The lines inside the circle of this symbol do not represent physical connections.

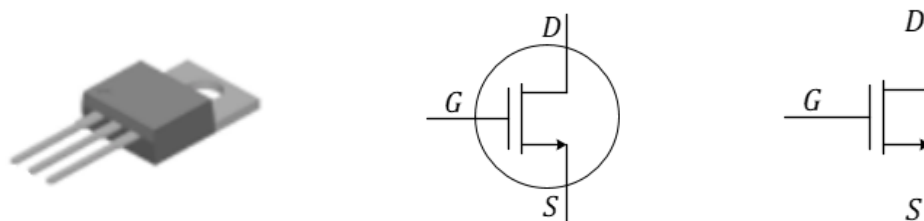
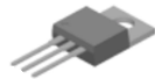

Figure 2: Physical appearance and two circuit symbols, both of which depict an n-channel MOSFET. In ECE 110, we typically use the right-most symbol (without the circle) for the nMOS device.

Notes:

MOSFET stands for Metal-Oxide-Semiconductor Field-Effect Transistor. While a transistor is typically used as a switch or amplifier, in this lab we use it as a variable resistor where a voltage from our circuit controls its resistance value!

Question 1: Use the datasheet to label the Drain, Gate, and Source of the nMOS device. Where in the



datasheet did you find this information?

This is our first look at a circuit device with three (and not just two) terminals. This is not a concern as we'll go ahead and place the nMOS "in a virtual box" with a strict voltage control between the Gate and Source terminals and allow only the Drain and Source terminals to exit the box (see Figure 3). It is *this* two-terminal sub-circuit whose IV characteristics we will now examine.

Figure 3 shows an "idealized" current-voltage model for our nMOS under a very-limited set of conditions (which we will not discuss here). The main take-a-way point is that the IV characteristic is not a single plot, but rather an infinite number of plots (a "family" of plots) that depend on the internal setting of V_{GS} within our sub-circuit. If $V_{GS} = 0$, the IV characteristic lies on the horizontal axis (like the IV characteristic of a resistor with $R_{eff} = \infty \Omega$). As V_{GS} increases, so does the slope of the IV plot as the *effective resistance* of circuit C , as viewed by the outside of the box, **approaches** $R_{eff} = 0 \Omega$...a short-circuit!

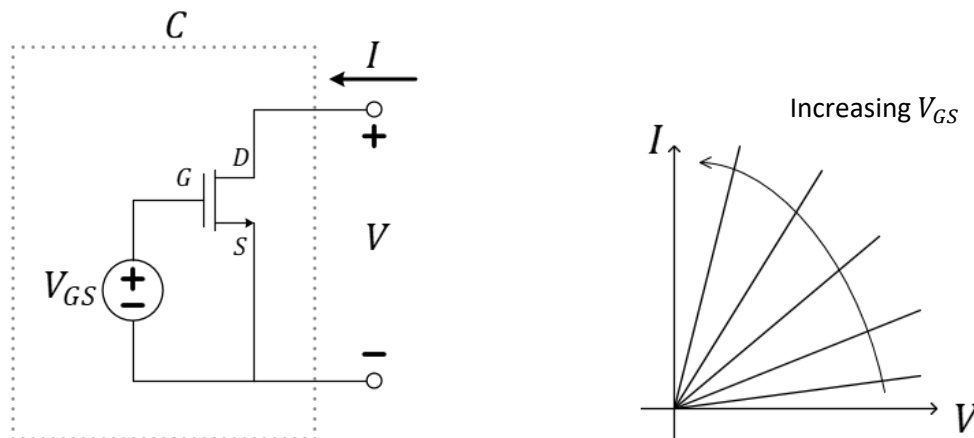

Figure 3: Controlling the nMOS and investigating its IV characteristics as a two-terminal circuit.

At this point, we have a way to tune a voltage source, V_{GS} , in order to control a variable resistance provided by an nMOS device. This doesn't at first seem any more advantageous than tuning the potentiometer...except, the voltage V_{GS} need not come from a dedicated variable voltage supply but can actually be provided by any other voltage in your circuit! Consider replacing the

voltage source with, say, the photo-resistor-enabled voltage divider from our cloud detector circuit as we have done in Figure 4. Just as with the Schmitt-trigger inverter, you can assume that the gate pin of the nMOS draws no current and thus the left-two components of this circuit do function as a voltage-divider.

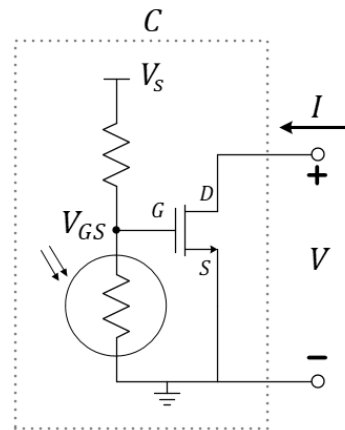

Figure 4: Controlling the effective resistance of the nMOS using light intensity.

Question 2: When using the voltage divider as shown in Figure 4 to control V_{GS} , does *high-intensity* light or *low-intensity* light cause **smaller** effective resistance between the drain and source terminals? Explain.

Finally, we have solved our issue of implementing a variable resistor that changes resistance based on the amount of available light and not on the direct input of a human. In Figure 5, we add the motor in “series” with the drain-to-source circuit of the nMOS transistor where the transistor acts as a current-limiting resistor to the DC motor. In the next section, we’ll build a light-controlled motor, while continuing to build our engineering curiosity!

Notes:

Comment: If this is your first time seeing this ground-node notation, please be aware that the symbol $\top V_s$ merely means that a voltage supply of value V_s has been connected between this node and the ground node \perp .

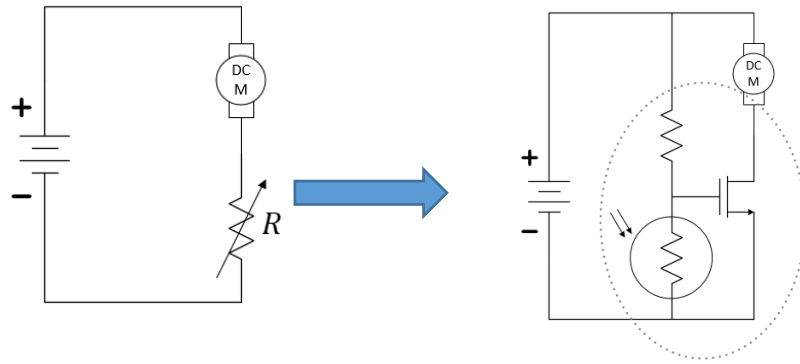

Figure 5: Replacing a mechanical variable resistor with an electronic one.

Notes:

Build

Construction Warnings!

There are several mistakes that you must avoid in this exercise. We are listing them here so that you can be careful as you move forward. Some mistakes can cause physical harm, so we'll start with that one.

- The nMOS transistor **must have** the motor between the Drain and the positive side of the battery. Why? If you connect the Drain to the positive side of the battery and the Source to the negative side of the battery, then, when the transistor's Drain-to-Source resistance drops low, you will have essentially shorted your battery. The high current flowing through the transistor will make the transistor get **very hot!** It will likely burn your fingers.
- Another common mistake (related to the one above) is to accidentally attach the motor across the power rails. The motor needs to be connected **between** the positive power rail and the Drain. As mentioned above, the Drain should **not** be connected directly to the power rail. *We can't emphasize that enough.*
- The motors are "symmetric" meaning that it will run no matter which way you plug it in (red vs black wires). It will merely change direction. The warning is: you want your car to go forward. If you find that one or both wheels is moving the wrong direction, just reverse the wires for that motor to correct it. There is no physical danger here.
- Damaging a potentiometer is easier than you may think! Common errors include turning the wiper with a heavy force near the ends of its mechanical limits. Damage can also occur when using it as a variable resistor and accidentally tuning its value into the range where power dissipation exceeds its rating.



The construction of a light-seeking car is now collapsed to a combination of nine electronic components! You will need your car chassis (specifically, one of its two DC motors), a photoresistor, a $10\text{ k}\Omega$ potentiometer (labeled with 103 to be used as a variable resistor), a 30N06L nMOS transistor, and your 9 volt battery. And don't forget your breadboard, M2k, and wire kit!

In this design, we again use of the potentiometers (3362R-103LF-ND, <https://www.mouser.com/ProductDetail/Bourns/3362R-1-103LF?qs=fCVTrKU7SHhTM6Zk6txpow%3D%3D>) as variable resistors is not to directly control motor speed, but rather to provide a means for tuning our voltage-divider.

Notes:

Step 1: Build one voltage divider and tune it.

With your power rails oriented horizontally, build a voltage divider across the right-hand-side of your board between one red and one black/blue power rail as shown in Figure 6 using your potentiometer and your photo-resistor. Before attaching your battery, gently adjust the potentiometer towards the **center** of its mechanical limits. This will be somewhere around $5\text{ k}\Omega$. Now, it will be safe to attach the 9-volt battery between the power rails.

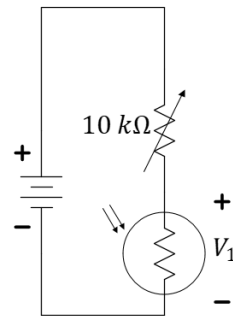

Figure 6: A voltage-divider utilizing a photo-resistor.

Use 1+ and 1- (the orange and orange/white connectors) on the M2k to measure the voltage across the photo-resistor, V_1 in Figure 6. Try to tune your potentiometer such that the voltage when held in bright light is below 2 volts and when held in the shadows is greater than 6 volts. You have only one knob to control, so do not spend a lot of time on this.

Question 3: What range of voltages did you see in your choice for “shadow” and “bright light”? This is not the first time you have used the photoresistor. Does this match your expectations? Explain.

Step 3: Add an nMOS and resistor.

Remove your battery. Follow these instructions to build the circuit as shown in Figure 7. Add the nMOS to your breadboard so that the three pins are in three separate “nodes” of the breadboard. Use a free space on your breadboard near the voltage-divider and connect (using wires if necessary) the gate pin of the nMOS to the center of the voltage divider and the source pin to

Reminder: Potentiometer used as a variable resistor...



Use the center lead plus **one** of the outer leads to create a variable resistor. Insert the unused lead into an unused row of the breadboard, but **do not cut it off!** Tune your value of the $10\text{ k}\Omega$ pot using this “screwdriver”:



the negative rail of the battery. Place a $1\text{ k}\Omega$ resistor between the positive power rail and the drain of the nMOS. Use the M2k to monitor the voltage across both the $1\text{ k}\Omega$ resistor, V_1 , as well as between the drain and source pins of the nMOS, V_2 .

Attach your battery. If necessary, gently adjust the potentiometer so the voltage across the $1\text{ k}\Omega$ resistor goes between 0 volts (the nMOS acting like an open circuit) and the battery voltage (the nMOS acting like a short circuit) as you use your hand to shadow and un-shadow the photo-resistor. As you adjust the potentiometer, be careful not to shadow it with your hand...you want the natural light and shadows in the room to control it.

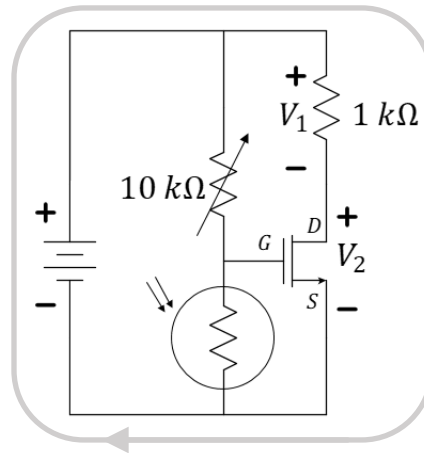

Figure 7: A simple schematic of a light-seeking robotic car.

Question 4: Describe the general mathematical relationship between V_1 and V_2 using Kirchhoff's voltage law around the outside of Figure 7.

****For your individual video submission.**** Replace the motor with the $1\text{ k}\Omega$ resistor and create a video that shows both movement of V_1 and V_2 as well as the movement of your hand altering the light on the photo-sensor.