



Educational Package Ventilation

Lecture 8: Sizing mechanical ventilation systems

IEE/09/631/SI2.558225
28.10.2011

Summary

- ☀ Introduction
- ☀ Air Flow : Relation between air flow, air speed and duct section...
- ☀ Ventilation design methodology:
 1. Ventilation calculation
 2. Number of fans & grilles
 3. Drawings
 4. Size duct work
 5. Size fan
 6. Size grilles & diffusers
- ☀ Duct cleaning
- ☀ Heat loss by ventilation
- ☀ How the sizing and placement of the ventilation ducts and unit influence the architecture

▶

Introduction

Mechanical ventilation:

- The process of changing air in a closed space
- Indoor air is drawn and replaced by fresh air continuously from a clean external source

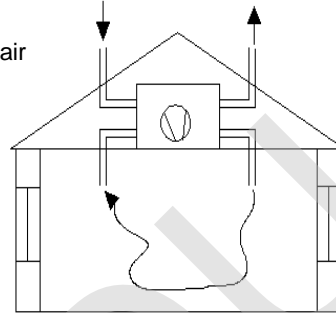

Mechanical or "forced" ventilation :

- ❖ is used to control indoor air quality
- ❖ need to protect the airway

Volume vs. Pressure ventilation:

- **Volume ventilation:** Volume is constant and pressure will vary with patient's lung compliance.
- **Pressure ventilation:** Pressure is constant and volume will vary with patient's lung compliance.

Air Flow Generalities

- ▶ **Airflow** – the mass/volume of air moved between two points
- ▶ **Air speed** – the speed of the air relative to its surroundings

Duct air moves

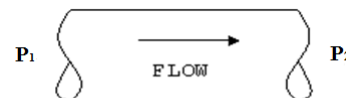

$$P_1 > P_2$$

3 fundamental laws:

- conservation of mass;
- conservation of energy;
- conservation of momentum.

Conservation of mass:

$$V_2 = (V_1 * A_1) / A_2$$

Where: **V** - velocity
A - area

Energy conservation : (Pressure loss)₁₋₂ = (Total pressure)₁ - (Total pressure)₂

Calculation of Flow Rate

Using Velocity and Duct Size:

❖ Circular Area : $A = \frac{\pi \cdot (d)^2}{4}$

❖ Rectangular Area: $A = x \cdot y$

❖ Flowrate: $Flowrate = v \cdot A$

Where:

A - area

d - diameter of duct

x - horizontal dimension of duct

y - vertical dimension of duct

v - velocity

▶ 5

Using Differential Pressure and a K Factor

Flowrate: $Flowrate = \sqrt{p \cdot K_f}$

Where:

p - differential pressure

K_f - K factor

Air Change Rates

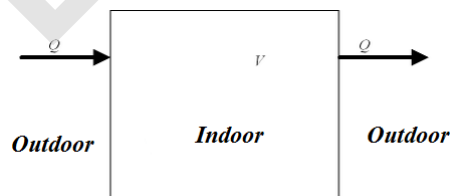

Imperial Units: $n = 60 q / V$

Where:

n - air change rate per hour

q - fresh air flow through the room
(Cubic Feet per Minute, *cfm*)

V - volume of the room (Cubic Feet)

▶ www.EngineeringToolBox.com

SI Units: $n = 3600 q / V$

Where:

n - air change rate per hour

q - fresh air flow through the room (m^3/s)

V - volume of the room (m^3)

6

Ventilation Design Methodology

1. What areas need ventilation? The contaminants should be listed for these areas.
2. What type of system should be used, supply, extract or balanced?
3. Are there any alternative systems to consider?
4. Is air conditioning necessary in the building? If air conditioning is necessary then should it be incorporated into the ventilation system?
5. Where should the fan(s) and plant be installed?
6. What type of fan(s) and plant should be used?
7. Is a separate heating system necessary?
8. What type of control system should be used?
9. What type of air distribution system should be used, upward or downward?
10. Have I considered what will happen in the event of a fire in the building?
11. Have I considered the noise from fans?

▶ 7 <http://www.arca53.dsl.pipex.com/>

Sizing Methodology

Sum of all debits brought into or removed
 \geq
 Sum of all flow rates of premises occupied

PRINCIPLES that must be respected

If the installation is simple flux the mechanical flows must be achieved when the openings are in the normal open position.

Feed rates and Evacuation lifts should be achieved when:

- all interior doors are normally closed;
- openings transfer are normally

The requirements in flow must be able be adhered to:

- wind speeds $< 4 \text{ m/s}$;
- temperature differences (within - Outside) $< 25^\circ \text{C}$.

The vents (mouth of a drive or mouth extraction)

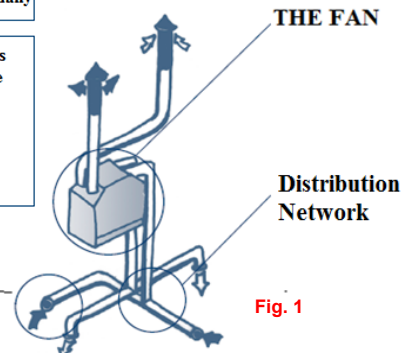

▶ www.EngineeringToolBox.com

8

Sizing procedure:

1. Calculate Ventilation rates.
2. Decide on number of fans and grilles/diffusers.
3. Draw scale layout drawing:
 - ▶ Position fan (s)
 - ▶ Lay out ductwork.
 - ▶ Lay out grilles and diffusers.
 - ▶ Indicate flow rates on drawing.
4. Size ductwork
5. Size fan
6. Size grilles and diffusers.

▶ 9 http://www.arca53.dsl.pipex.com/index_files/vent7.htm

Design Criteria

2 basic requirements:

- To supply fresh air for the occupants
- To change the air in the room sufficiently so that smells, fumes and contaminants are removed.

▶ 10 http://www.arca53.dsl.pipex.com/index_files/vent7.htm

1. Ventilation Calculations

1.1 For General Mechanical Ventilation

Ventilation rate (m³/h) = Air Change Rate (/h) x Room Volume (m³)

Ventilation rate (m³/s) = Ventilation rate (m³/h) / 3600

1.2 For Calculating Fresh Air Ventilation Rates

Fresh Air Rate (m³/s) = Fresh Air rate per person (l/s/p) x nr of occupants

▶ http://www.arca53.dsl.pipex.com/index_files/vent7.htm

2. Number of Fans and Grilles

- Several fans are often better than one since it makes the ventilation system more flexible. Also the air to be supplied or removed may be in different areas of a room or building where individual fans can be more effective.
- The number of grilles or diffusers may depend on the ceiling layout, lighting layout and amount of air to be transferred.

▶ 12

3. Drawings

Accurate, scaled plan drawings are necessary for installation, fabrication, estimating and commissioning a ventilation scheme.

Drawings should show:

1. Flow rates of air;
2. Ductwork to scale with sizes indicated.
3. Air flow direction
4. Items of plant

▶ 13

4. Size Ductwork

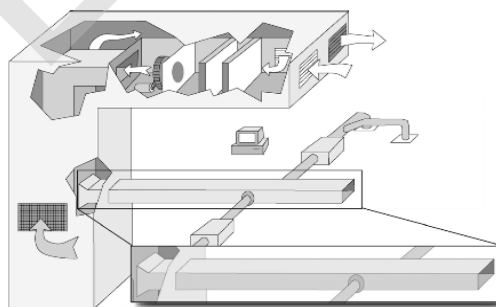

Fig. 2

Duct design is as much an art as it is a science; however, some rules of thumb and guidelines are presented to help designers develop a cost-effective and energy-efficient duct design

Size Ductwork

Ductwork is classified according to static pressure of the air as follows:

Ductwork Class	Pressure Classification	Static Pressure Limit (Pa)	
		Positive	Negative
A	Low Pressure	500	500
B	Medium Pressure	1000	750
C	High Pressure	2000	750

Duct Sections

The maximum length of a duct section depends on the size of the longer side. The sections can be flanged at each end, transported to site and bolted together in-situ.

► 15 http://www.arca53.dsl.pipex.com/index_files/vent7.htm

3 methods of designing ductwork and fan:

- **Equal velocity method** - the designer selects the same air velocity for use through out the system
- **Velocity reduction method** - the designer selects variable velocities appropriate to each section or branch of ductwork
- **Equal friction method** - the air velocity in the main duct is selected and the size and friction determined from a design chart. The same frictional resistance is used for all other sections of ductwork

Size Ductwork

- ▶ For conventional **low velocity** ductwork the sizing method most used is by **constant pressure**, that is, the average pressure or resistance to flow per unit length is kept at a constant figure.
- ▶ The duct sizing chart (Figure below) shows the various pressure drops against air quantity or volume and duct diameter.

▶ 17 http://www.arca53.dsl.pipex.com/index_files/vent7.htm

Size Ductwork

Figure 1:
The duct sizing chart:
flow of air in circular ducts

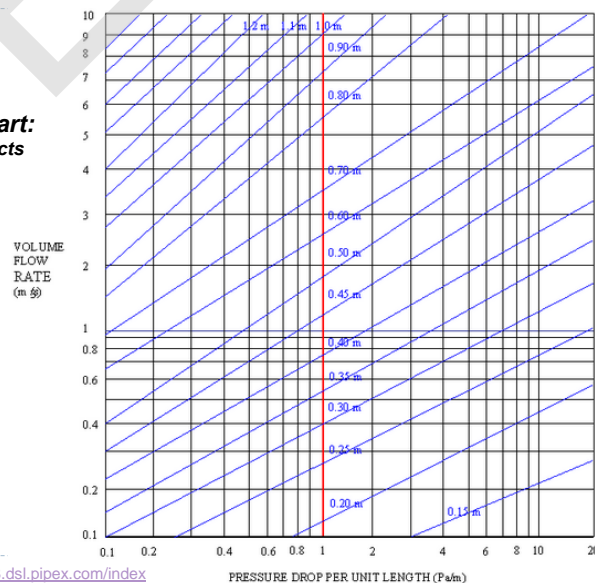

Fig. 3

▶ 18 <http://www.arca53.dsl.pipex.com/index>

Size Ductwork

By selecting an appropriate **pressure drop**, the required duct diameter can be selected for any given air volume.

When using **Figure I** any resistance per unit length can be selected.

Some designers use values as shown below:

1. **Quiet** - Pressure drop 0.4 Pa/m.
2. **Commercial** - Pressure drop 0.6 Pa/m.
3. **Industrial** - Pressure drop 0.8 Pa/m.

▶ ¹⁹ http://www.arca53.dsl.pipex.com/index_files/

Duct Sizing Using Equal Pressure Drop Method

1. Choose a rate of pressure drop and keep this constant for the whole system e.g. **1.0 Pa per meter run**.
2. **Size ductwork** using Figure I (Duct Sizing Chart) if the volume flow rate of air is known.
 - ▶ This will give the duct diameter.
3. Determine the equivalent size of **rectangular** duct if required by calculation
4. Calculate the actual air velocity from:

$$\text{Air velocity (m/s)} = \text{Volume flow rate (m}^3\text{/s)} / \text{CSA}$$

Where:

CSA - Cross sectional area of duct (m²)

▶ ²⁰ http://www.arca53.dsl.pipex.com/index_files/

Duct Sizing Using Equal Pressure Drop Method

Fittings Pressure Loss

5. Determine the velocity pressure factors (**z zeta**) for the fitting(s) in each section of ductwork from CIBSE Guide C (2007) Section 4.10.
 6. Determine the velocity pressure (**V.P.**) by calculation or by using CIBSE Guide C (2007) Table 4.19.
- ❖ **The actual air velocity will be that obtained from section 4 above.**

$$V.P. = 0.5 \times r \times v^2$$

Where:

- V.P.** - Velocity pressure (Pa)
r - Density of air (1.2 kg/m³)
v - Air velocity (m/s)

▶ ²¹ http://www.arca53.dsl.pipex.com/index_files/

Duct Sizing Using Equal Pressure Drop Method

7. Multiply z factors x V.P. to give total pressure loss for fittings.
Pressure loss for fittings (Pa) = z factors x V.P.

Where:

- V.P.** - Velocity pressure (Pa)
z factor - Pressure loss factor for a fitting from CIBSE guide C (2007) Section 4.10.

Total Pressure Drop in Section

8. **Pressure loss in straight duct (Pa) = Rate of pressure drop (1.0 Pa per metre run) x length of section (m)**
9. **Total Pressure drop in Section (Pa) = Pressure loss for fittings (Pa) + Pressure loss in straight duct (Pa)**

▶ ²² http://www.arca53.dsl.pipex.com/index_files/

Pressure Loss in Fittings

Zeta (z) factors are to be used with the **Velocity Pressure** to find fittings resistances.

Zeta (z) factors are pressure loss factors.

These allow for the resistance of fittings in ductwork systems which can be quite significant compared to straight runs of duct.

Pressure Loss (l resistance) (Pa) = zeta factor (z) x Velocity Pressure (Pa)
and

$$\text{Velocity Pressure (Pa) V.P.} = 0.5 \times r \times v^2$$

Where:

V.P. - Velocity pressure (Pa)

r - Density of air (1.2 kg/m³)

v - Actual air velocity (m/s)

▶ ²³ http://www.arca53.dsl.pipex.com/index_files/

Duct Sizing Table

- ▶ The duct sizing table shown below is an aid to duct sizing.
- ▶ The explanation for use is given in the table below.
- ▶ A blank table is included in this section at the end

Blank table below:

Duct Sizing Table												
1	2	3	4	5	6	7	8	9		10	11	12
Section	Length (m)	Flow rate (m ³ /s)	Pressure dropper metre (Pa/m)	Duct size (mm)	Velocity (m/s)	Pressure (Pa)	Fittings Pressure Loss factor or ξ (zeta factor)	Pressure loss		Total Pressure Loss (Pa)	Cumulative Pressure Loss (Pa)	
								Fittings (Pa)	Straight Duct (Pa)			

▶ ²⁴ http://www.arca53.dsl.pipex.com/index_files/

Some Duct Sizing Aids

1. Divide the system into sections.
2. A section is from one branch to another or in parts of the system with a steady volume flow rate.
3. Size the index circuit first, that is the circuit with the highest resistance to air flow. There is only one circuit in the above scheme so the index circuit includes sections A,B,C,D. Normally the index circuit is the longest circuit, but not always so check if necessary.
4. Branches should be included in the downstream section, for example the first branch in the above system should be allowed for in section B resistance calculations. (This means that the Zeta factor for the branch is multiplied by the correct velocity pressure, that is the smaller velocity pressure as indicated in CIBSE C (2007) Table 4.19.)
5. Contractions should be included in the downstream section rather than the upstream section for the same reason as in part 4.

▶ 25 http://www.arca53.dsl.pipex.com/index_files/

Equivalent Diameter

The equivalent diameter - diameter of a circular duct /pipe => gives the same pressure loss as an equivalent rectangular duct or pipe.

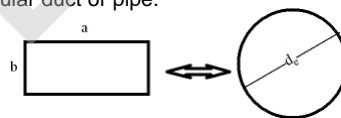

$$d_e = 1.30 \times ((a \times b)^{0.625} / (a + b)^{0.25})$$

Where:

- d_e - equivalent diameter (mm, inches)
- a - length of major or minor side (mm, inches)
- b - length of minor or major side (mm, inches)

▶ 26 www.EngineeringToolBox.com

Oval Equivalent Diameter (Ellipse)

$$d_e = 1.55 A^{0.625} / P^{0.2}$$

where

A = cross-sectional area oval duct (m², in²)

P = perimeter oval duct (m, inches)

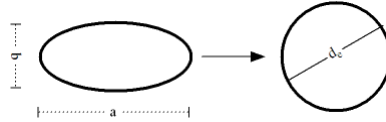

The cross-sectional area of an oval : $A = \pi a b / 4$

Where:

a = major dimension of the flat oval duct (m, in)

b = minor dimension of the flat oval duct (m, in)

The perimeter of an oval duct (ellipse) can be approximated to $P \approx 2 \pi (1/2 ((a/2)^2 + (b/2)^2))^{1/2} (2b)$

Oblong Ducts

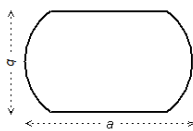

$$d_e = 1.55 (\pi b^2 / 4 + a b - b^2)^{0.625} / (\pi b + 2 a - 2 b)^{0.25}$$

engineeringtoolbox.com

▶ 27 www.EngineeringToolBox.com



5. Types of fan:

- ❖ Cross-flow or tangential
- ❖ Propeller
- ❖ Axial flow
- ❖ Centrifugal

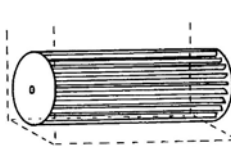
• Cross-flow or tangential fan



▶ 28

Fan Capacity Diagrams

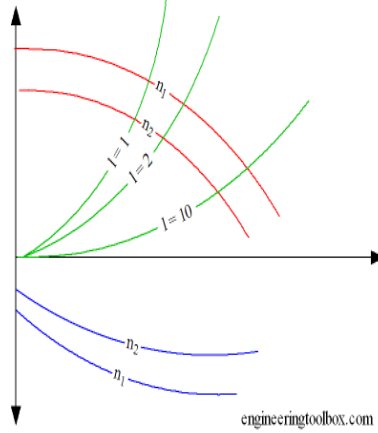

engineeringtoolbox.com

- **The red lines** are the pressure head as a function of the air flow volume and the speed of the fan.
- **The green lines** marked - I - are the throttle lines
- **The blue lines** are the power consumption of the fan

$p_t = p_s + p_d = \text{constant}$ (1)

Where:
 p_t - total pressure (Pa, N/m²)
 p_s - static pressure (Pa, N/m²)
 p_d - dynamic pressure (Pa, N/m²)

The dynamic pressure:
 $p_d = \rho v^2 / 2$ (2)

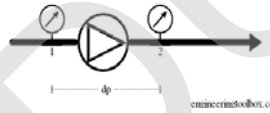

Where:
 ρ - density of air (kg/m³)
 v - flow velocity (m/s)



Head developed by the fan :
 $dp = p_{s2} - p_{s1} + (v_2^2 - v_1^2) \rho / 2$ (3)

Where:
 subscription : 1 & 2 - the inlet of the fan and outlet

▶ <http://www.engineeringtoolbox.com> 29

Choosing Fans

- Provide the motive for air movement (imparting static energy or pressure and kinetic energy or velocity)
- It's capacity for air movements depends on:
 - **Type**
 - **Size**
 - **Shape**
 - **Number of blades**
 - **Speed**

Basic law of fan capabilities (at a constant air density):

1. Volume of air varies in direct proportion to the fan speed :

$$\frac{Q_2}{Q_1} = \frac{N_2}{N_1}$$

Where:
 Q – volume of air (m³/s)
 N – fan impeller (rpm)

▶ « Mechanical Ventilation », Mohd Rodzi Ismail, School of Housing Building & Planning 30

Choosing Fans

2. Pressure of, or resistance to, air movement is proportional to fan speed squared :

$$\frac{P_2}{P_1} = \left(\frac{N_2}{N_1}\right)^2$$

Where:
P – pressure, [Pa]

3. Air and impeller power is proportional to fan speed cubed :

$$\frac{W_2}{W_1} = \left(\frac{N_2}{N_1}\right)^3$$

Where:
W – power, [W] or [KW]

As fans are not totally efficient, the following formula may be applied to determine the percentage:

$$\text{Efficiency} = \frac{\text{Total fan pressure} \times \text{air volume}}{\text{Absorbed power (W)}} \times \frac{100}{1}$$

▶ 31 « Mechanical Ventilation », Mohd Rodzi Ismail, School of Housing Building & Planning

Characteristic curves of a fan

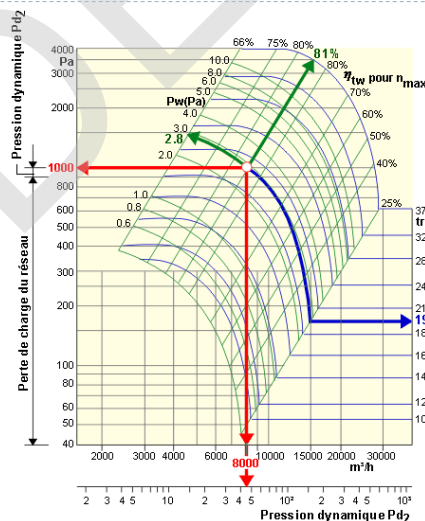

Characteristic curves of a fan

They represent the evolution of the main features of the fan speed depending on the volume of supply air.

This is related to the gain curves of total pressure, the power of the fan shaft, the overall yield curve and the curve of sound power level.

▶ 32

Characteristic curves of a fan

Total pressure difference between inlet and an outlet fan:

$$\Delta p = p_{ts} - p_{te}$$

It can also be expressed as a height h of gas transported or water column.

$$\Delta p = \rho g h$$

with: g acceleration due to gravity,

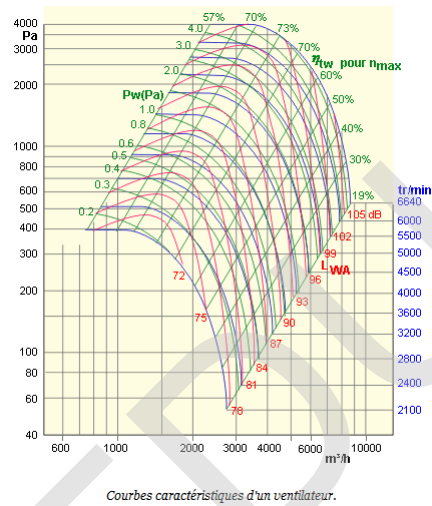

▶ 33

CHARACTERISTICS CURVES A FAN

The integration of the fan in the network plays a significant role on the overall performance installation:

- the output section of the fan be as much as possible adapted to the section of the duct distribution;
- must be provided at the output fan, a section of straight jacket long enough before the first change of direction

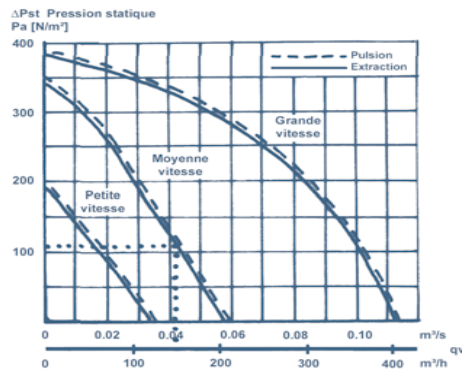

▶ 34

Choosing FAN

- ▶ we select first the fans whose curve passes through the point of operation.

- ▶ we spot on the characteristic curves of the manufacturer, the fan whose performances the maximum operating point.

▶ 35

Fan selection criteria

- **Redundancy** – a single fan or multiple fans;
- **Duty** – CFM and static pressure at design conditions;
- **First cost** – more efficient fans are often more expensive;
- **Space constraints** – a tight space may limit fan choices;
- **Efficiency** – varies greatly by type and sizing;
- **Noise** – different fan types have different acoustic performance;
- **Surge** – some fan selection are more likely to operate in surge at part-load conditions

▶ 36

6. Size Grilles and Diffusers

There are three criteria that determine diffuser size and number:

- **Throw**
- **Pressure loss**
- **Noise level**

▶ 37

Selecting grilles and diffusers

Grille - device for supplying or extracting air vertically without any deflection.

Diffuser normally has profiled blades to direct the air at an angle as it leaves the unit into the space, as shown below.

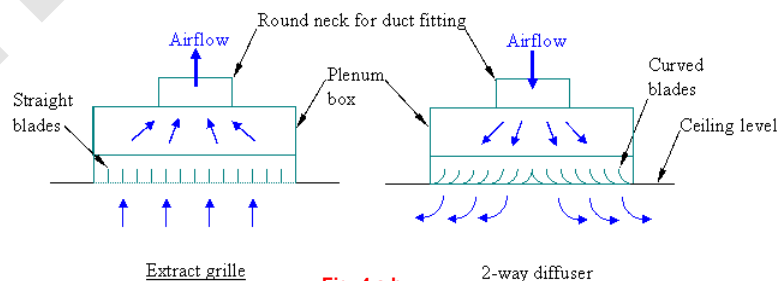



Fig. 4 a,b

Selecting grilles and diffusers



Grilles and Diffusers:

➔ can be manufactured in:

- Aluminium;
- Mild steel;
- Stainless steel;
- Plastic

➔ may be mounted in ceilings, floors, walls, doors and in ducts.

▶ « Mechanical Ventilation », Mohd Rodzi Ismail, School of Housing Building & Planning 39

Types of Grille and Diffuser

<p>Several types of grille & diffuser :</p> <ul style="list-style-type: none"> ➤ Egg grate grille; ➤ Bar grille; ➤ Transfer grille; ➤ Louvre bladed diffuser; ➤ Straight bladed diffuser; ➤ Linear slot diffuser; 	<p>Less commonly used diffusers:</p> <ul style="list-style-type: none"> ➤ Swirl diffuser; ➤ Floor outlet diffuser; ➤ Jet diffuser; ➤ Punkah diffuser; ➤ Barrel diffuser; ➤ Perforated diffuser; ➤ Valves; ➤ Plain face diffuser
------------------------------------------------------------------------------------------------------------------------------------------------------------------------------------------------------------------------------------------------------------------------------------------	----------------------------------------------------------------------------------------------------------------------------------------------------------------------------------------------------------------------------------------------------------------------------------------------------------------------

▶ « Mechanical Ventilation », Mohd Rodzi Ismail, School of Housing Building & Planning 40



Types of Grille and Diffuser



Egg crate grille **Fig. 6a**



4-way Louvre Bladed Diffuser



4-way Diffuser



2-way Corner Diffuser



Bar grille **Fig. 6b**



Circular Louvre Bladed Diffuser **Fig. 9 a,b**



Straight Bladed Diffuser for Duct Mounting



transfer grille **Fig. 8 a,b**



Sward Diffuser



Circular Floor Outlet



Jet Diffuser **Fig. 10 a,b,c,d**





Aluminium Pankah Diffuser



Perforated Face Diffuser

« Mechanical Ventilation », Mohd Rodzi Ismail, School of Housing Building & Planning 41

Design Criteria for Diffuser Design

'Nominal sizes' are the dimensions of the duct opening into which a register, grille or diffuser will fit.

- a) register and Grille sizes are based on the duct that they will cover; therefore the best method of sizing is to remove the Register or Grille and to measure the duct. Measurements are normally taken in inches: width A x height B as diagram below. (Note: the measurement in inches in each case is usually an even number).
- b) should removal of the Register or Grille not be possible at the time of measuring, measure the opening / grille area of the Register or Grille. Measurements are taken width A x height B as diagram below, then add approximately 1 inch to each dimension to find the nominal size of the replacement register or grille. (Note, the measurement in inches in each case is usually an even number).

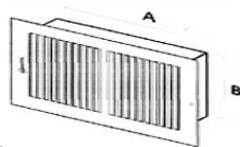
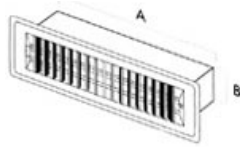



Fig. 11 a,b

« Mechanical Ventilation », Mohd Rodzi Ismail, School of Housing Building & Planning 42

Duct Cleaning

- Ducts may collect dirt and moisture, which can harbor or transport microbial contaminants.
- Ducts should be designed, constructed and maintained to minimize the opportunity for growth and dissemination of Microorganisms.
- Recommended control measures include providing access for cleaning, preventing proper moisture and dirt accumulation.

▶ [The National Air Duct Cleaners Associations NADCA : http://www.nadca.com](http://www.nadca.com)

43

Cleaning Phases

A cleaning can be divided into 5 phases:

- 1. Planning meeting**
- 2. The inspection**
- 3. The cleaning**
- 4. Proving**
- 5. Follow up**

▶ 44

Cleaning Phases

1. Planning meeting:

The system must be inspected in order to identify any problems.

2. The inspection:

The inspection serves to identify exactly where and to what extent problems exist. Often it is not enough to inspect visually, simply because it is not always possible to get into the duct. The inspection vehicle is an effective tool to get into the most distant parts of the system.

3. The cleaning:

The actual cleaning is carried out upon the basis of the inspection, and in a way that is the best for the given system. It might be relevant to perform a disinfection or coating of the system after the cleaning.

4. Proving:

The job is completed by examining the system together with the customer. It is recommended that a video inspection and record is made. This inspection is carried out in the same places where the first inspection was made. In this way it is possible to obtain data which can be compared.

5. Follow up:

After the final delivery, a service agreement with the customer can be arranged.

▶ 45

Heat loss by ventilation

$$H_v = c_p \rho q_v (t_i - t_o)$$

Where:

H_v - ventilation heat loss (W)

c_p - specific heat capacity of air (J/kg K)

ρ - density of air (kg/m³)

q_v - air volume flow (m³/s)

t_i - inside air temperature (°C)

t_o - outside air temperature (°C)

The heat loss due to ventilation with heat recovery can be expressed as:

$$H_v = (1 - \beta/100) c_p \rho q_v (t_i - t_o)$$

Where:

β - heat recovery efficiency (%)

▶

46

The sizing & the placement of the ventilation ducts influence the architecture and the energy use

Kitchens and bathrooms typically have mechanical exhaust to control odors and sometimes humidity.

Factors in the design of such systems include **the flow rate** (which is a function of the fan speed and exhaust vent size) and **noise level**.

➤ *The ducting should be insulated as well to prevent condensation on the ducting.*

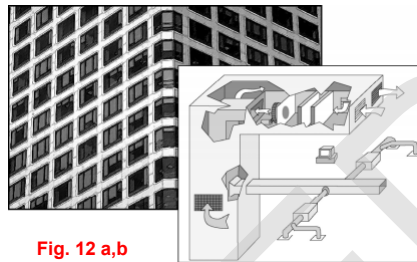

Fig. 12 a,b

► Wikipedia

47

In designing a system, it is important to anticipate:

- how it will be installed;
- how damage to historic materials can be minimized;
- how visible the new mechanical system will be within the restored or rehabilitated spaces.

► www.EngineeringToolBox.com

48



Minimize the impact of the mechanical ventilation systems on the existing architecture

- ▶ Design criteria for the mechanical ventilation systems should be based on the type of architecture of the historic resource.
- ▶ Consideration should be given as to whether or not the delivery system is visible or hidden.
- ▶ Utilitarian and industrial spaces may be capable of accepting a more visible and functional system.
- ▶ More formal, ornate spaces which may be part of an interpretive program may require a less visible or disguised system.
- ▶ A ducted system should be installed without ripping into or boxing out large sections of floors, walls, or ceilings.
- ▶ A wet pipe system should be installed so that hidden leaks will not damage important decorative finishes.
- ▶ In each case, not only the type of system (air, water, combination), but its distribution (duct, pipe) and delivery appearance (grilles, cabinets, or registers) must be evaluated.

=> It may be necessary to use a combination of different systems in order to preserve the historic building.

▶ "Heating, Ventilating, and Cooling Historic Buildings Problems and Recommended Approaches", Sharon C. Park, AIA 49



Conclusion:

Mechanical system selection is as much art as science. The choice that the designer makes must balance a wide range of issues including:

- ❖ first cost;
- ❖ energy cost;
- ❖ maintenance effort;
- ❖ coordination with other trades,
- ❖ spatial requirement, acoustics, flexibility, architectural esthetics, and many other issues.

▶ « Mechanical Ventilation », Mohd Rodzi Ismail, School of Housing Building & Planning

50

Good Ventilation Design

1. Not **noisy**
2. Concealed
3. No **draughts**
4. Efficient fan
5. Good **control of air** flow with dampers and appropriate diffusers.
6. Good control of room temperature.
7. Appropriate duct sizes.
8. Well supported ducts and equipment.
9. Prevent spread of smoke in the event of a fire with smoke/fire dampers.
10. Ensure that supply air is **clean** by using a filter.

▶ 51

Good Ventilation Design

11. Ensure that **vermin** cannot enter the duct system by using a bird/insect screen in the fresh air intake.
12. Minimise risk of **infection** in some buildings (e.g. hospital) by having no recirculation duct.
13. Use recirculation duct in some buildings to save energy.
14. Use appropriate air change rates to meet room requirements.
15. Use appropriate fresh air rate to meet room occupants' requirements.
16. Use suitable system to fit in with building aesthetics.
17. Avoid duct leaks by using proper **jointing method**

▶ 52

References:

1. [www. EngineeringToolBox.com](http://www.EngineeringToolBox.com)
2. « Mechanical Ventilation », Mohd Rodzi Ismail,
School of Housing Building & Planning
3. [http: www.arca53.dsl.pipex.com](http://www.arca53.dsl.pipex.com)

Levels for the Figures

Level 1, bring best quality to the material: Get permission to use the original picture.

Level 2, medium quality: Redraw the illustration

Level 3, poor quality: replace the illustration with a link or a reference to where to find the illustration.

Figure Number	Level (1- 3)
Fig 1	3
Fig 2	3
Fig 3	3
Fig.4 a,b	3
Fig.5 a,b	3
Fig.6 a,b	3
Fig.7 a,b,c	3
Fig.8	3
Fig.9 a,b	3
Fig.10 a,b,c,d	3
Fig.11 a,b	3
Fig.12 a,b	3