

5V ISOLATION RELAY MODULE



Description

The isolation relay module is an electrically operated switch that allows you to turn on or off a circuit using voltage and/or current much higher than a microcontroller could handle. There is no connection between the low voltage circuit operated by the microcontroller and the high power circuit. The relay protects each circuit from each other.

The module has three connections named NC, COM, and NO. Depending on the input signal trigger mode, the jumper cap can be placed at high level effective mode which 'closes' the normally open (NO) switch at high level input and at low level effective mode which operates the same but at low level input.

Specifications

- Onboard EL817 photoelectric coupler with photoelectric isolating anti-interference ability strong.
- Onboard 5 v, 10 A / 250 VAC, 10 A / 30 VDC relays, relay long life can absorb 100000 times in a row.
- Module can be directly and MCU I/O link, input signal trigger mode (high level effective mode and low level effective mode) can be choose by jumper cap.
- Module with the instructions and signal output diode current protection
- PCB size: 46 (mm) x17.6 (mm).

Pin Configuration

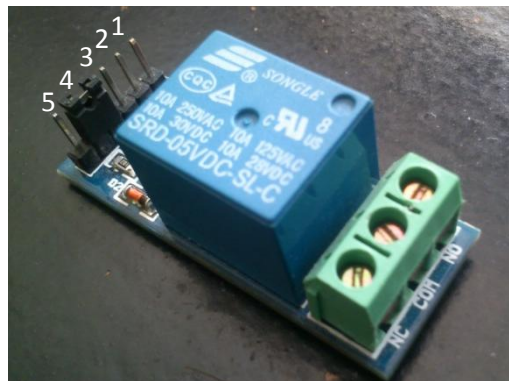

1. VCC: 5V DC
2. 5V DC alternate positive power source
3. Input signal trigger (high level effective mode)
4. Jumper cap, 5V DC alternate negative power source
5. GND: ground

Wiring Diagram

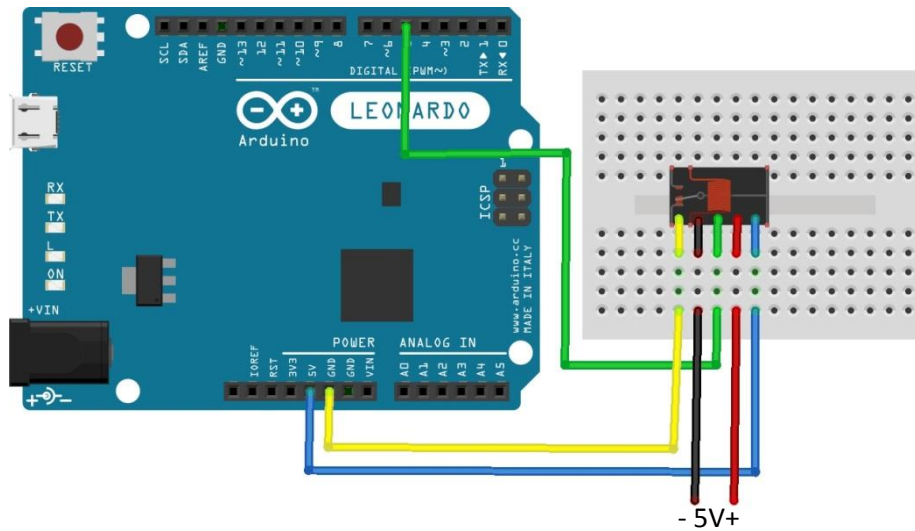

Schematic Diagram

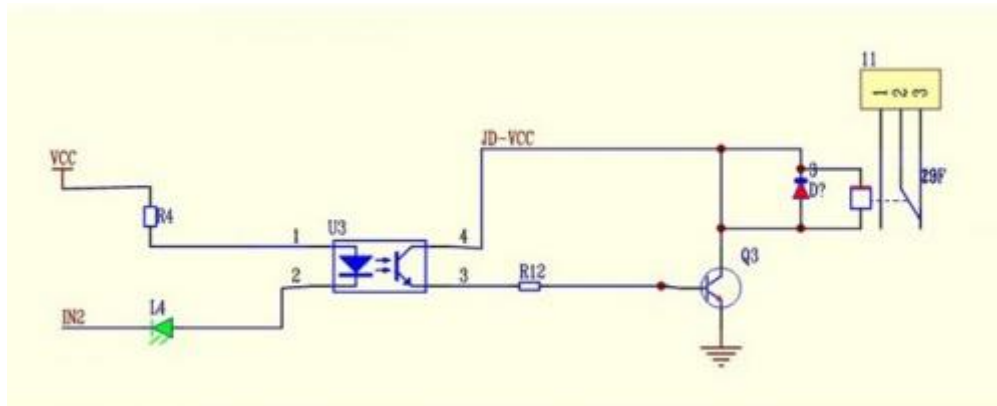

Sample Sketch

```
void setup(){
  digitalWrite(5, LOW);
  pinMode(5, OUTPUT);
  delay(4000);
}

void loop(){
  digitalWrite(5, HIGH);
  delay(4000);
  digitalWrite(5, LOW);
  delay(4000);
}
```

How to test

The components to be used are:

- Microcontroller (any compatible arduino)
 - 5V isolation relay module
 - M-M pin connectors
 - F-F pin connectors
 - Breadboard
 - USB cable
1. Connect the components based on the figure shown in the wiring diagram using M-M and F-F pin connectors. VCC pin is connected to the 5V power supply, GND pin is connected to the GND, and the input pin is connected to the digital I/O pin. Pin number will be based on the actual program code.
 2. After hardware connection, insert the sample sketch into the Arduino IDE.
 3. Using a USB cable, connect the ports from the microcontroller to the computer.
 4. Upload the program.

Testing results

The figure below shows the first 4 seconds at start up and the COM and NC should be connected.

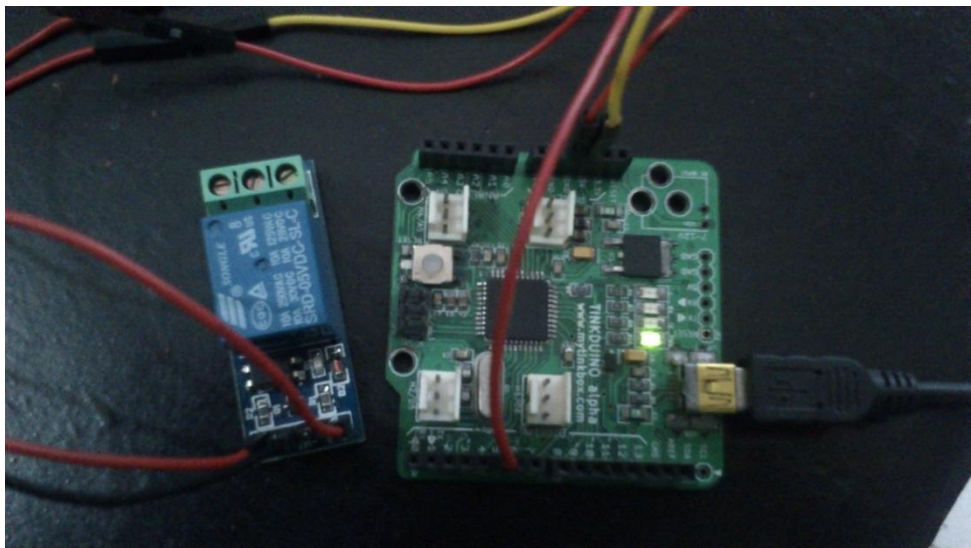

After 4 seconds, the COM and NO should now be connected and a tick sound along with a red LED would be observed.

